



6.7L Cummins Drop-In Filtration System INSTALLATION MANUAL

DIFSRAM4001



2019-2023
6.7L Cummins

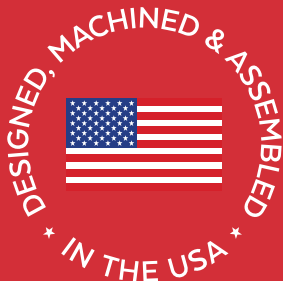

Note: Cab and Chassis
may require modifications



FASS DIESEL FUEL SYSTEMS® / ENGINEERED EXCELLENCE

RAM



www.fassride.com

(866) 769.3747

Thank you for choosing FASS, from Diesel Performance Products, Inc.

FASS specializes in building extremely high-quality fuel products. We have earned an unsurpassed reputation for excellence in our industry by using only the highest-quality American-made components. In order to support our American workers and our American economy, more than 98+ percent of our products are manufactured completely in the United States.

Of course, that dedication to excellence comes at a price, but it is important to remember that price does not dictate quality-quality dictates price! We will never compromise by using cheaper, foreign-made components, like so many of our competitors do.

Customer satisfaction is our top priority and we strive always to provide outstanding customer service. Our Research and Development department, in conjunction with our Dealer Support Department, continually searches for ways to improve quality, expand our product line, and provide superb support. Our exclusive ViP Network ensures that customers receive the proper products and support at the local level. The extended lifetime warranty is only available on products purchased from the network. There is no warranty on products not purchased outside the network.

IMPORTANT:

In order to qualify for the lifetime extended warranty, your product registration form and proof of purchase from an authorized dealer must be submitted to FASS Fuel Systems within 30 days of purchase. Failure to comply will void the warranty. We have the right to deny any warranty believed to be false, altered or purchased through an unauthorized or terminated dealer. A current list of authorized dealers can be found on our website, FASSRide.com.

The complete conditions of the Limitation of Warranty can be found in the back of this manual, and FASSRide.com.

**For more information,
contact Technical Support:
Diesel Performance Products, Inc.
16234 State Hwy O
Marthasville, MO 63357
636-433-5410**



WARNING!

This product has NO WARRANTY unless:

- 1. It has been purchased from an **Authorized** or **ViP FASS Dealer**. If in doubt, check www.FASSRide.com.**
 - 2. It is registered within thirty (30) days of purchase.**
- Other conditions may apply. Please see full warranty information.**

***NOTE:* Warranty is **void** if product was purchased below FASS website advertised pricing.**

ATTENTION!

Before you begin installation

Register for your Warranty ONLINE at

<https://www.fassride.com/register-a-warranty/>

No online access, call our TECH Support at

1-866-769-3747

FOLLOW THESE STEPS TO ENSURE A SIMPLE, CORRECT INSTALLATION OF YOUR NEW DROP-IN FUEL SYSTEM

ATTENTION:

Be sure to identify the proper FASS System and fuel line configuration. For help, our product finder can be found at www.FASSride.com. Follow the instructions to see fuel line detail.

- 1** Be sure the serial number on this installation manual matches that on the outside of the box.
- 2** Pay close attention to ALL WARNINGS
- 3** Read all instructions before starting installation of this product.
- 4** Inventory the package components. Notify the place of purchase immediately of any parts missing or damaged.
- 5** The installation recommendations contained herein are guidelines. Use good judgment and take into consideration your vehicles' accessories.
- 6** For best results in accuracy and efficiency (due to training, communication, and our relationship with our dealer network), we recommend a VIP FASS dealer for the installation. They are prepared to install the FASS fuel pumps with the most efficiency. If a situation or problem arises during the installation, the dealer is prepared to handle it. Diesel Performance Products, Inc. is not responsible for any installation mistakes.
- 7** If you have any questions or concerns that cannot be addressed with your dealer, email or call FASS.

**If any installation procedure is uncertain, contact FASS technical support.
Call customer service at 636-433-5410,
or send us an e-mail: techsupport@FASSride.com
with the following information:**

Your name, address and daytime phone number Model

DIFSRAM4001

Serial Number

Last 6 digits of vehicles' VIN

Date of purchase

Nature of Your Concern

Serial number

Serial # >



INSTALLATION MANUAL

DIFSRAM4001

(Installation Videos are available at
www.fassride.com)

- 1. Read all instructions before starting installation of this product!**
- 2. Installing the improper FASS Pump can cause severe engine damage.**
- 3. Secure vehicle from ROLLING!**
- 4. Consult vehicle's manufacturers' instructions concerning the electrical system before attempting any electrical connections.**
- 5. Be sure that the serial # on this installation manual matches that of the outside of the box.**
- 6. Flush and clean all brass fittings and fuel line from debris.**
- 7. Keep debris from entering the internals of the system during installation.**
- 8. Wear safety glasses when operating power tools such as drills and grinders or when using a punch or chisel.**
- 9. Properly secure lines to prevent chaffing.**

CONTENTS

NOTE: Owner's Manual available for download on our website, www.FASSride.com



PFB-2002



DIFS-UNI-BRKT-1001



MP-9097



DIFS-RAM-WH-1001



FL-1010x12'



FL-1001x16'

MOUNTING PACKAGE CONTENTS

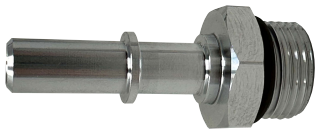

8-ORB-375-QC

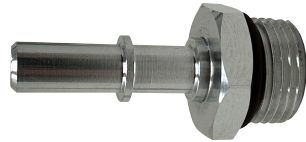

10-ORB-375-QC



QPD3B-05F-04-05M



**(TWO)
A614M53-08-02**



A624M53-08-02



**(THREE)
HC-1001**



**(THREE)
WA-1001D**



DIPF-1003

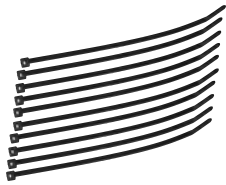

CABLE TIES



HC-4001



**(FOUR)
LOCKING NUT 3/8"**

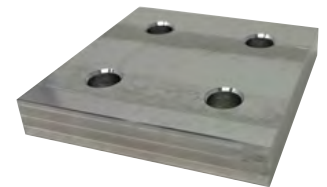

GMCSPCR-1001



WIFS2001



PL-1002



PL-1012



**(FOUR)
3/8" WASHERS**



**(FOUR)
HEX BOLT
3/8"-16x2-1/4"**



**(THREE)
HEX BOLT
1/4"-20x1-3/4"**

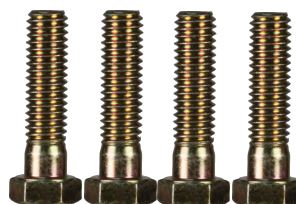

**(FOUR)
HEX BOLT
3/8"-16x1-1/2"**



DIFS-RAM-WH-4001

The images below show the proper steps for disconnecting and connect the quick-connect style fuel lines.

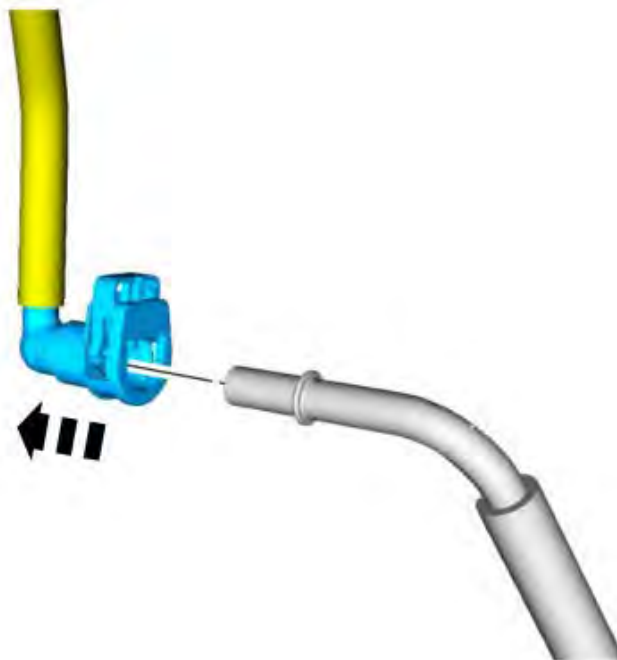
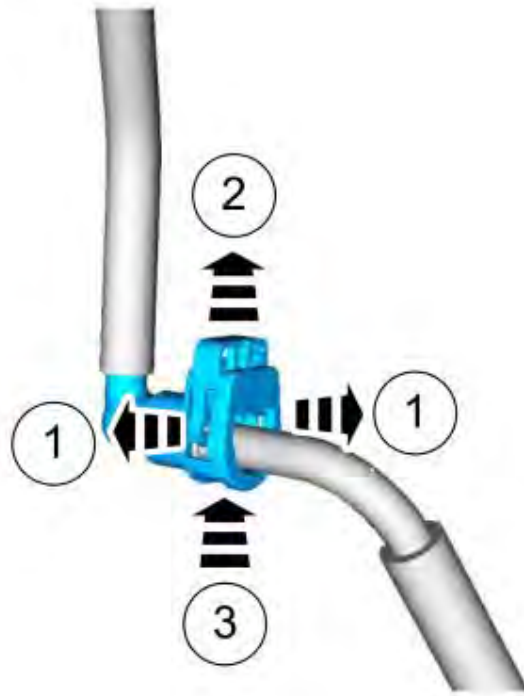

The images below show the proper steps for disconnecting and connect the quick-connect style fuel lines.

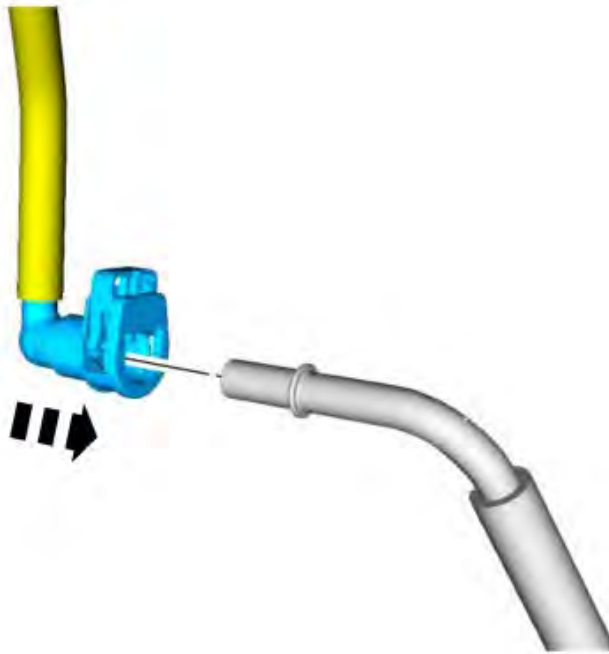

The images below show the proper steps for disconnecting and connect the quick-connect style fuel lines.

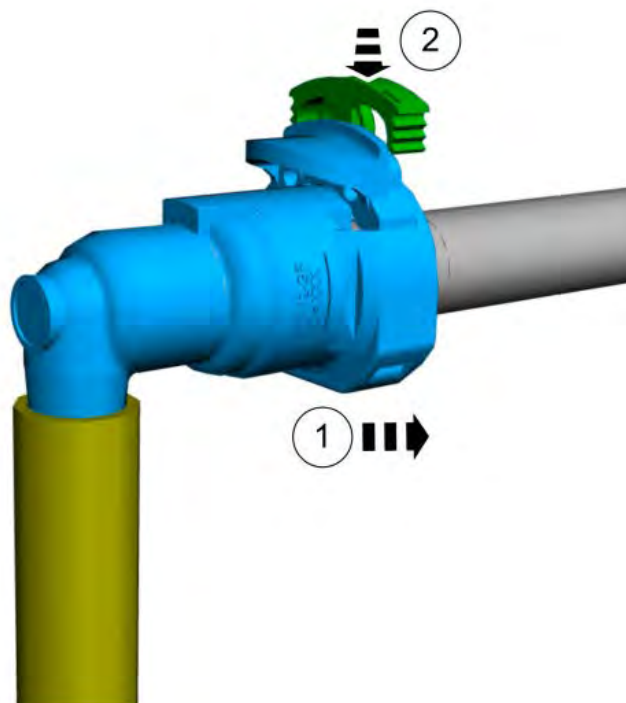
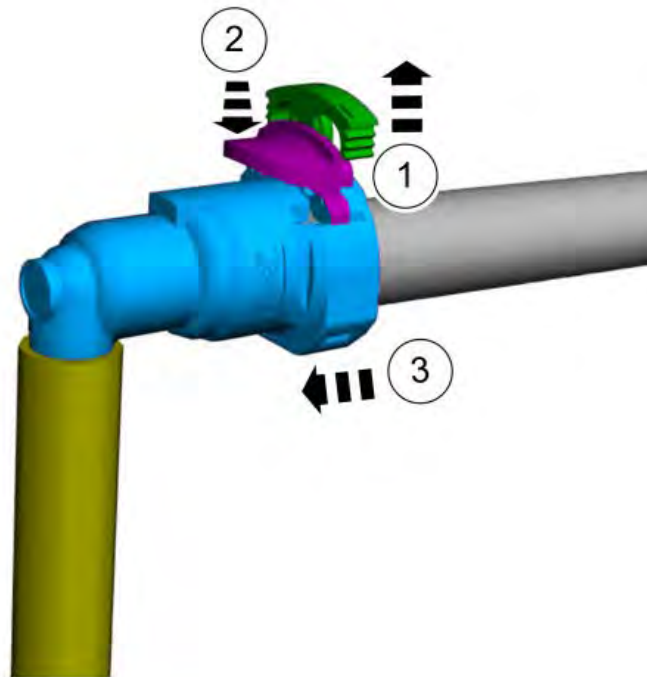

NOTE: ON TRUCKS WITHOUT THE OEM REAR MOUNTED FUEL FILTER WATER SEPARATOR SKIP TO STEP E.

A. Place a drain pan under the OEM rear mounted fuel filter housing assembly and drain the water separator.



B. Release the locking tabs and disconnect the two fuel lines from the OEM rear mounted filter housing and the electrical connector.

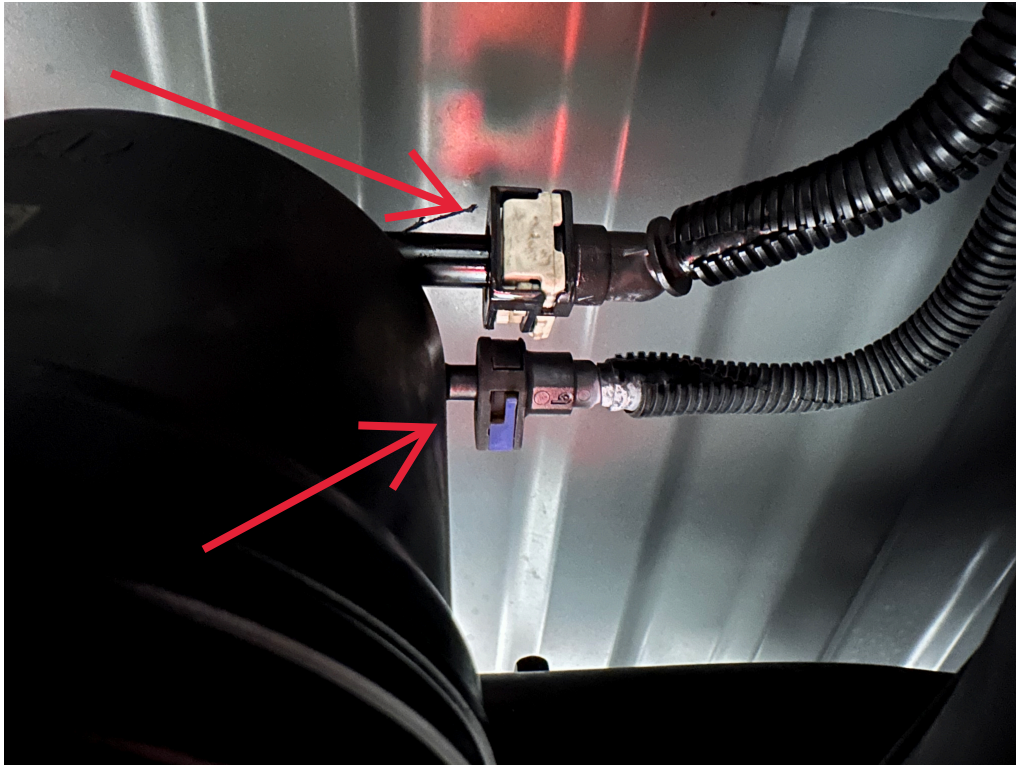

C. Remove the OEM rear mounted filter from the housing assembly. Using a 13mm socket remove the two bolts holding the housing assembly to the mount and remove the housing assembly.

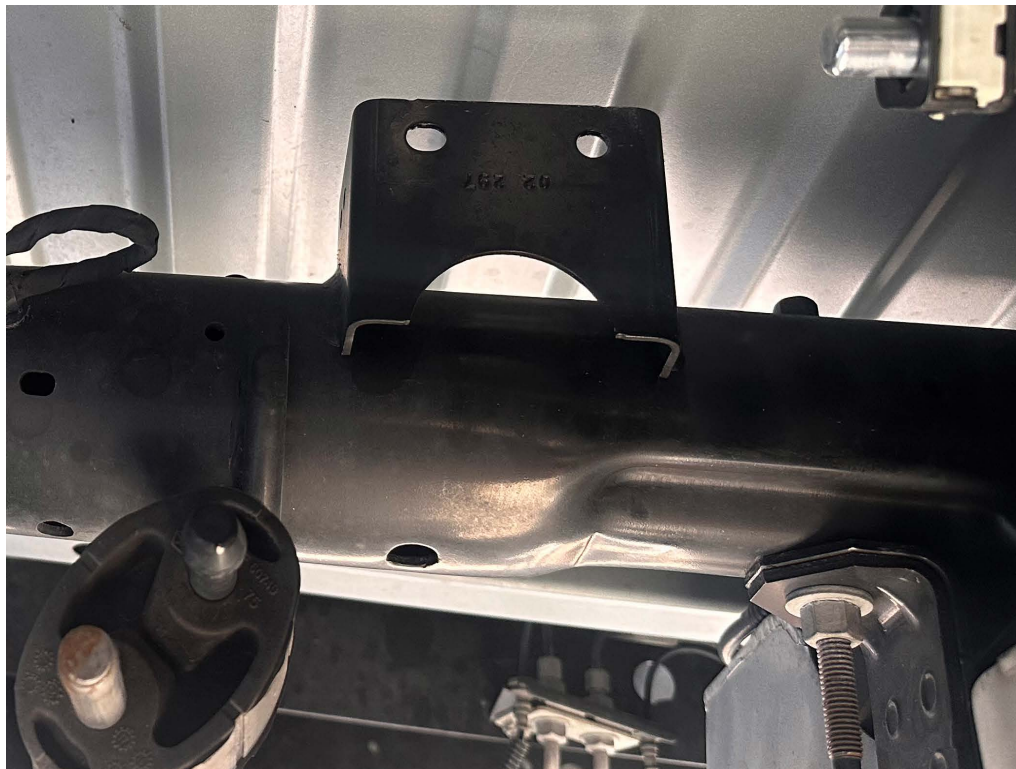
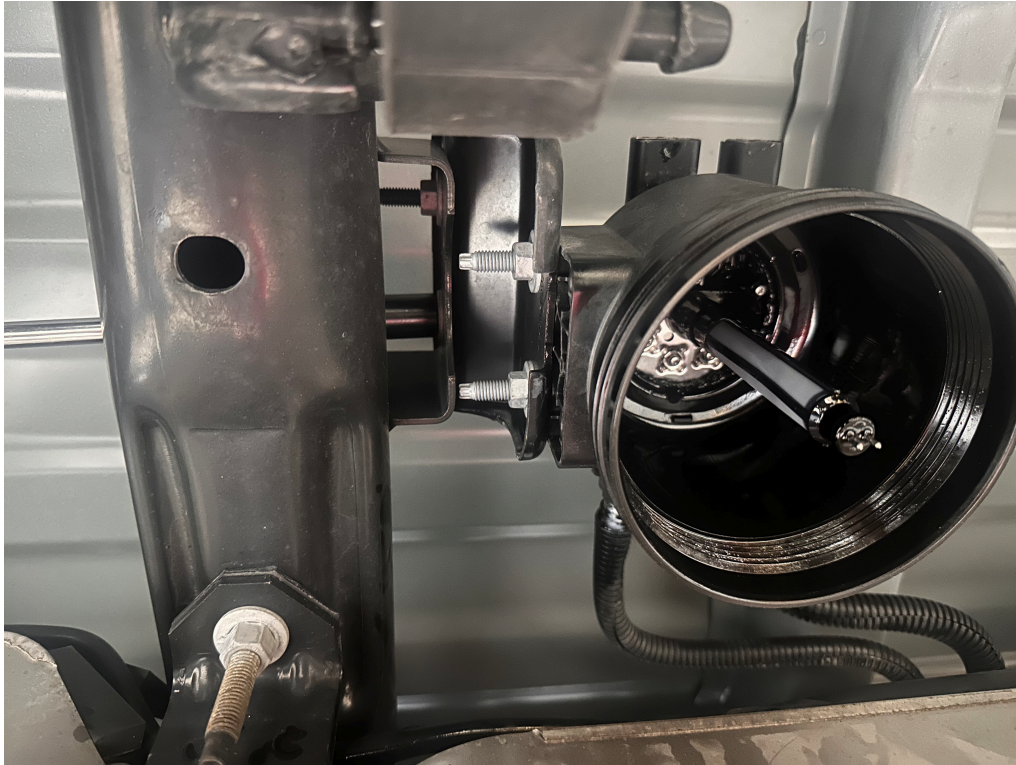

D. Install DIFS-RAM-WH-4001 into the OEM rear WIF sensor connector.



E. Place a drain pan under the OEM fuel filter housing assembly and drain the water separator.

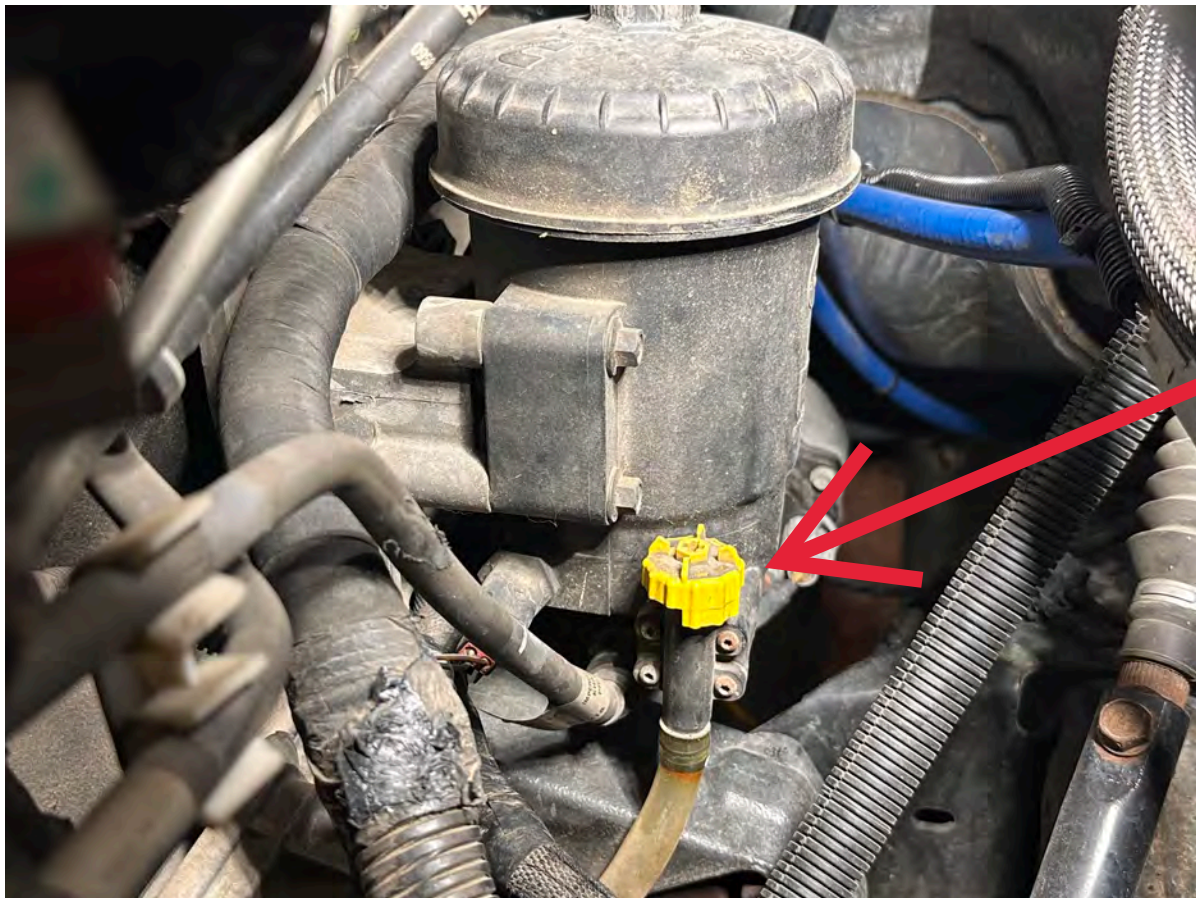

F. Install 10-ORB-375-QC into the fuel manifold and 8-ORB-375-QC into the open rear port on the FASS. Tighten both fittings accordingly.



G. Place the three 1/4" bolts through DIFS-UNI-BRKT-1001 with the three supplied aluminum spacers. Place the bracket onto the FASS and tighten accordingly.

NOTE: BRACKET CAN BE FLIPPED TO ACCOMMODATE YOUR APPLICATION

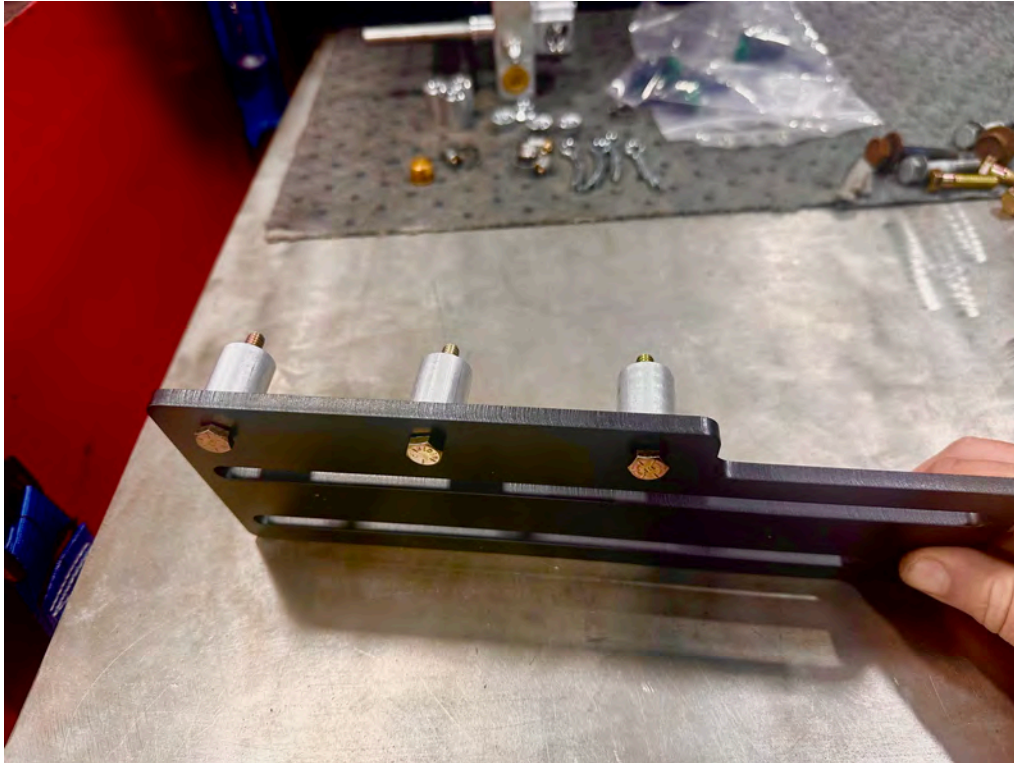

H. Remove the driver side front bed bolt and discard.



I. Place the supplied M12-1.75 X 60MM Hex Bolt through the supplied washer and PFB-2002 with the supplied spacer. Secure the bracket in the OEM bed bolt hole location and tighten accordingly.

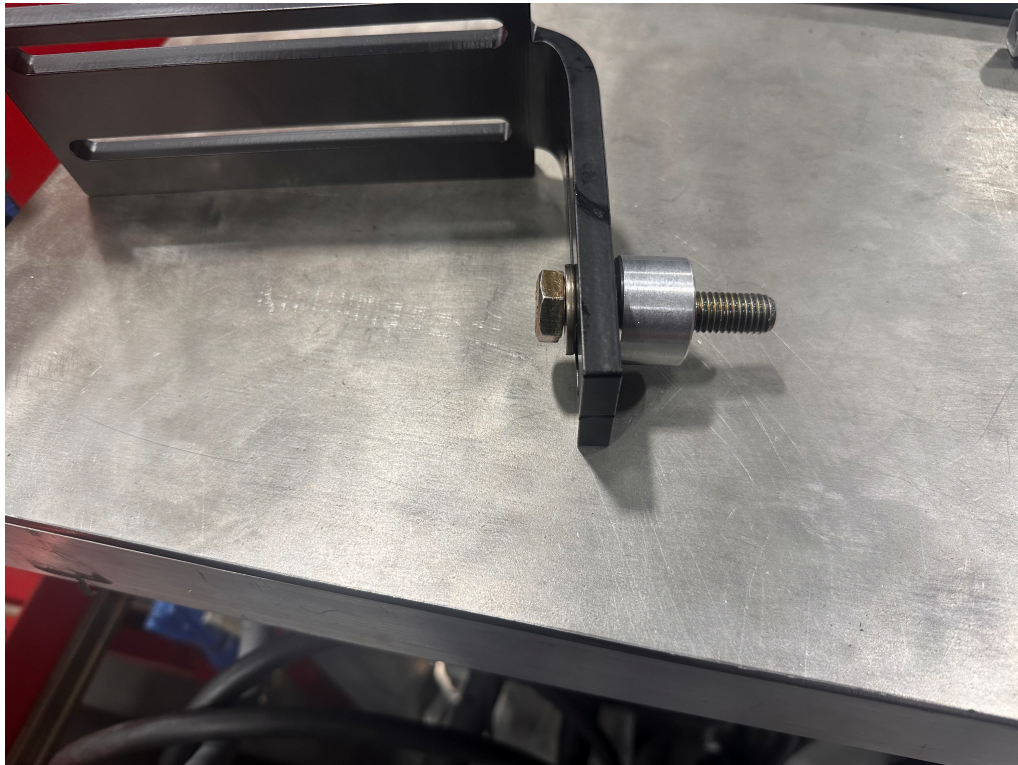

J. Place the four 3/8" bolts through the supplied washers and DIFS-UNI-BRKT-1001 with the supplied aluminum spacer GMCSPCR-1001. Place the bracket onto PFB-2002 using the four supplied locking nuts and tighten accordingly.

NOTE: TORQUE BOLTS NOT FLANGE NUTS

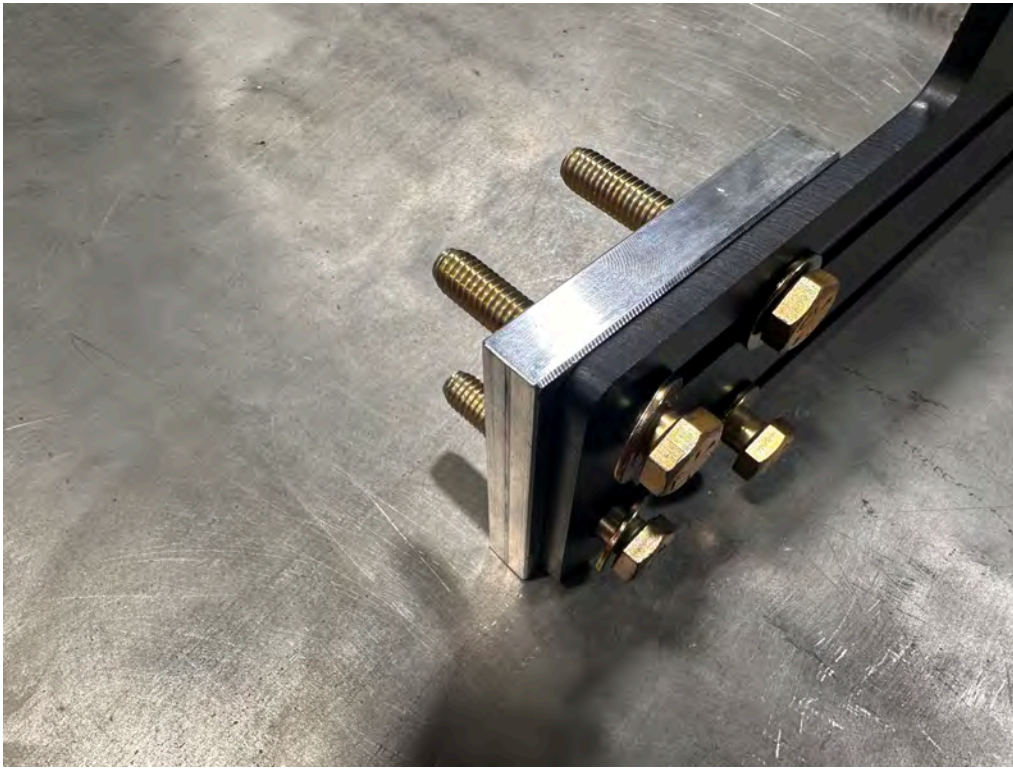

K. Remove the 3/8" OEM quick connect line from the fuel tank module.

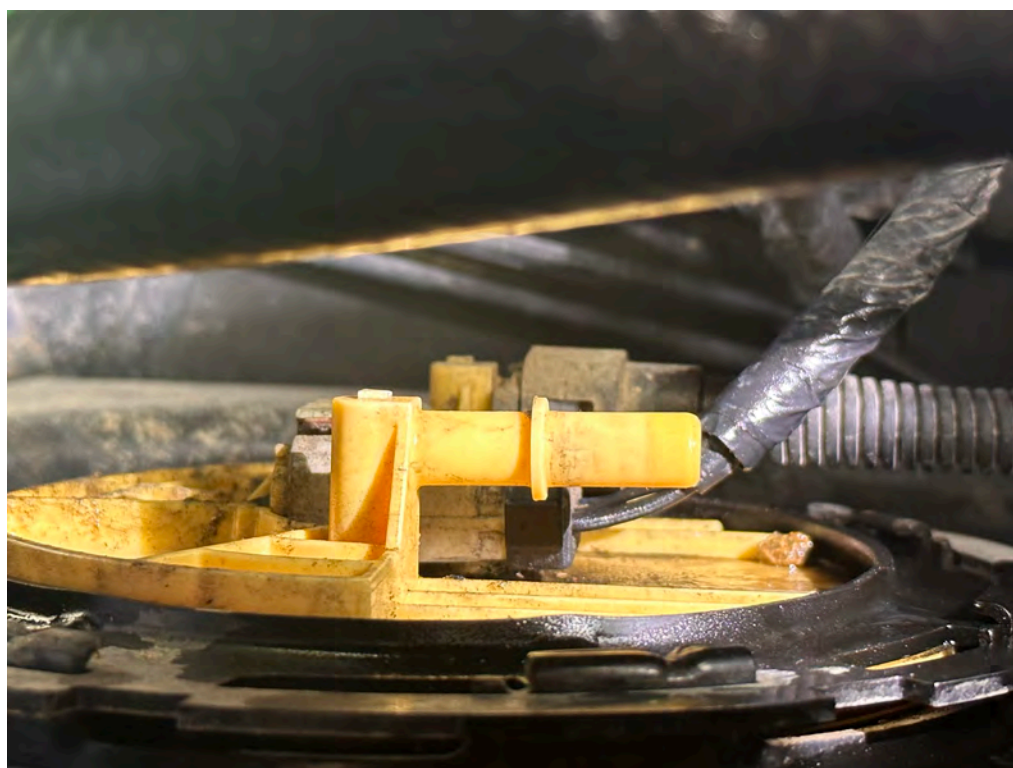
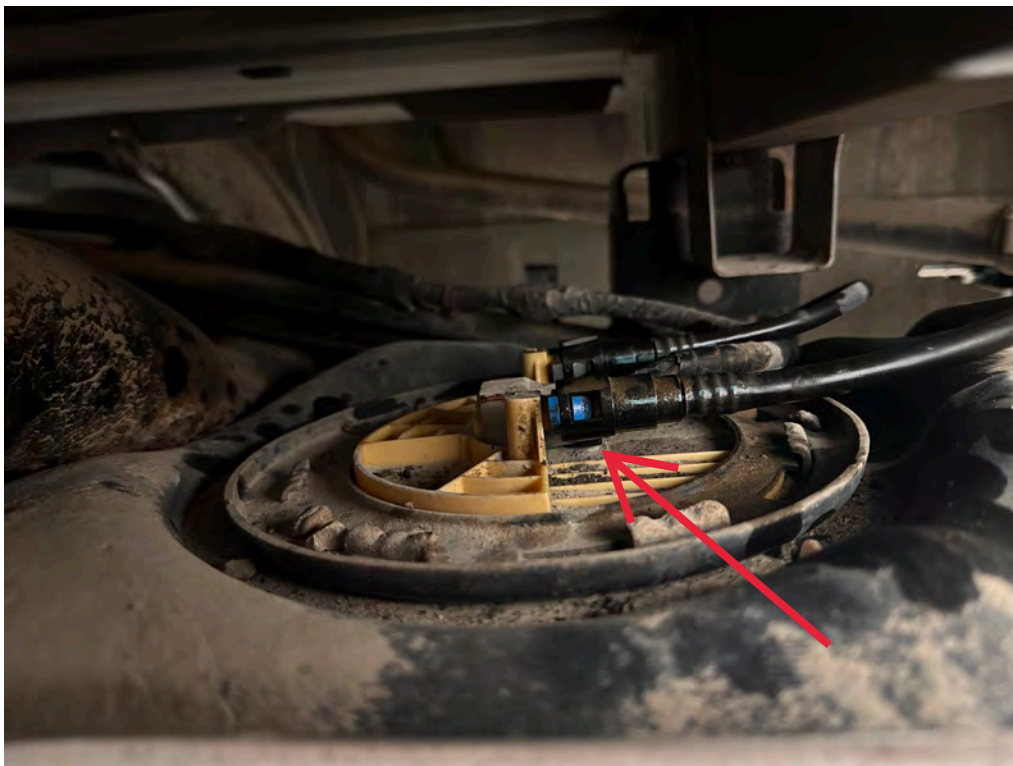

L. Using grease, press A624M53-08-02 into FL-1001 and secure using HC-1001. Install A624M53-08-02 onto the OEM 3/8" quick connect port and route FL-1001 to the FASS and trim accordingly.



M. Using grease, press A614M53-08-02 into FL-1001 and secure using HC-1001. Install A614M53-08-02 onto the FASS.



N. Disconnect the OEM fuel supply line from the CP3 then remove fitting.

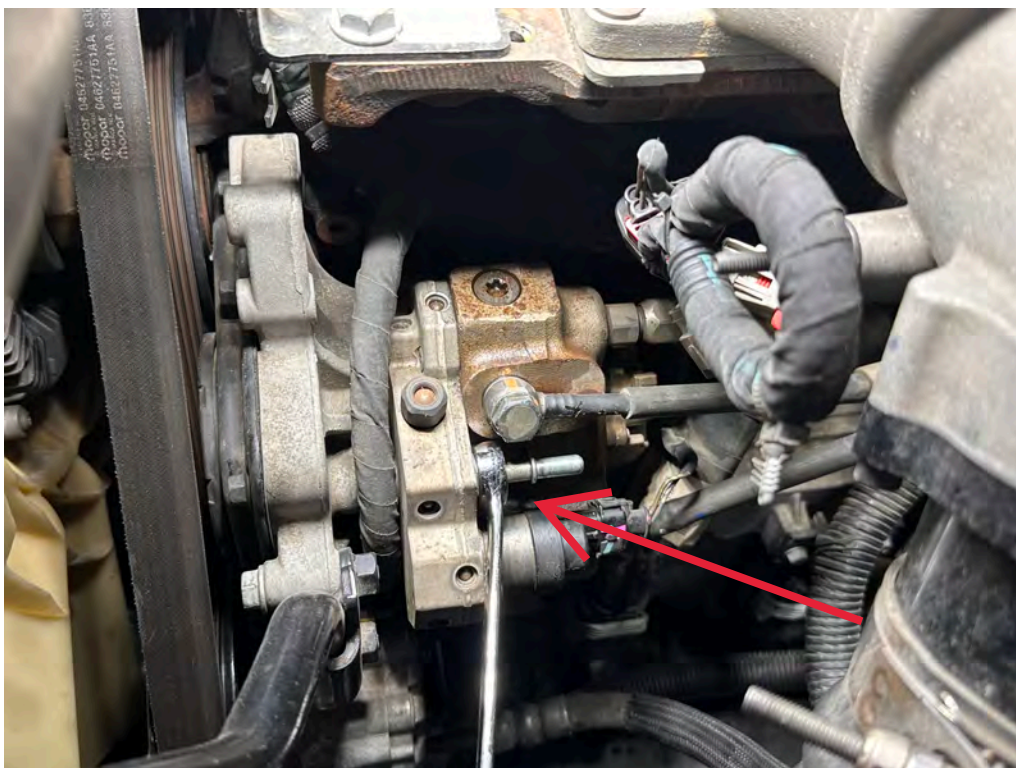
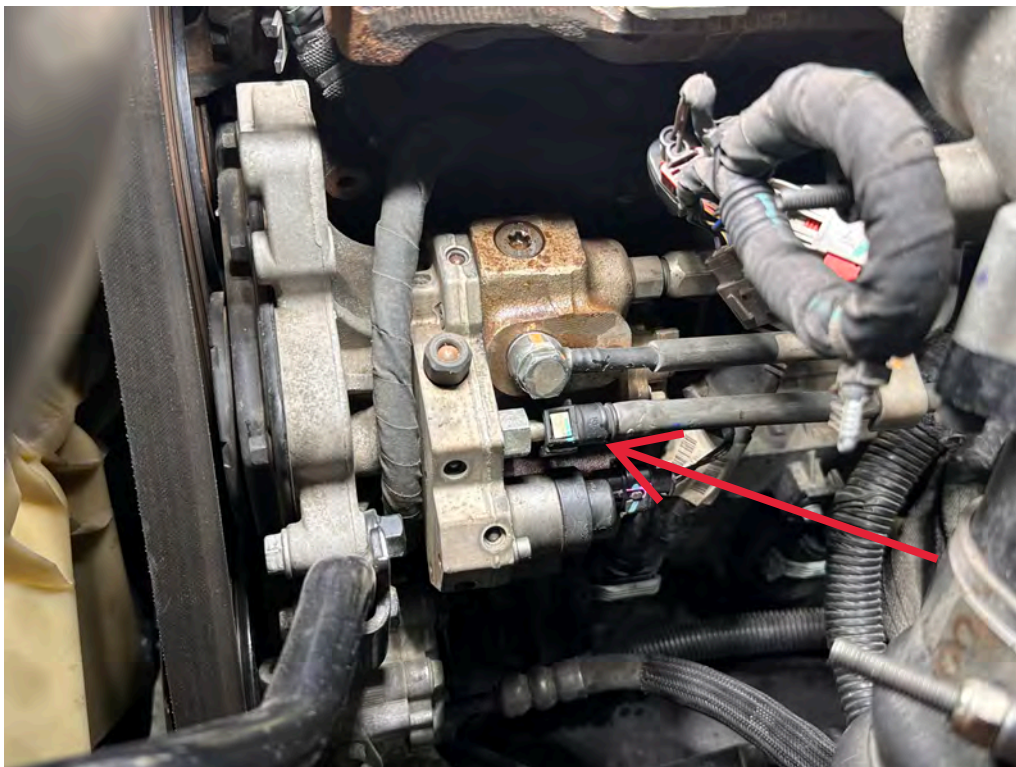

- O. Install DIPF-1003 in place of the OEM fitting and tighten accordingly.**

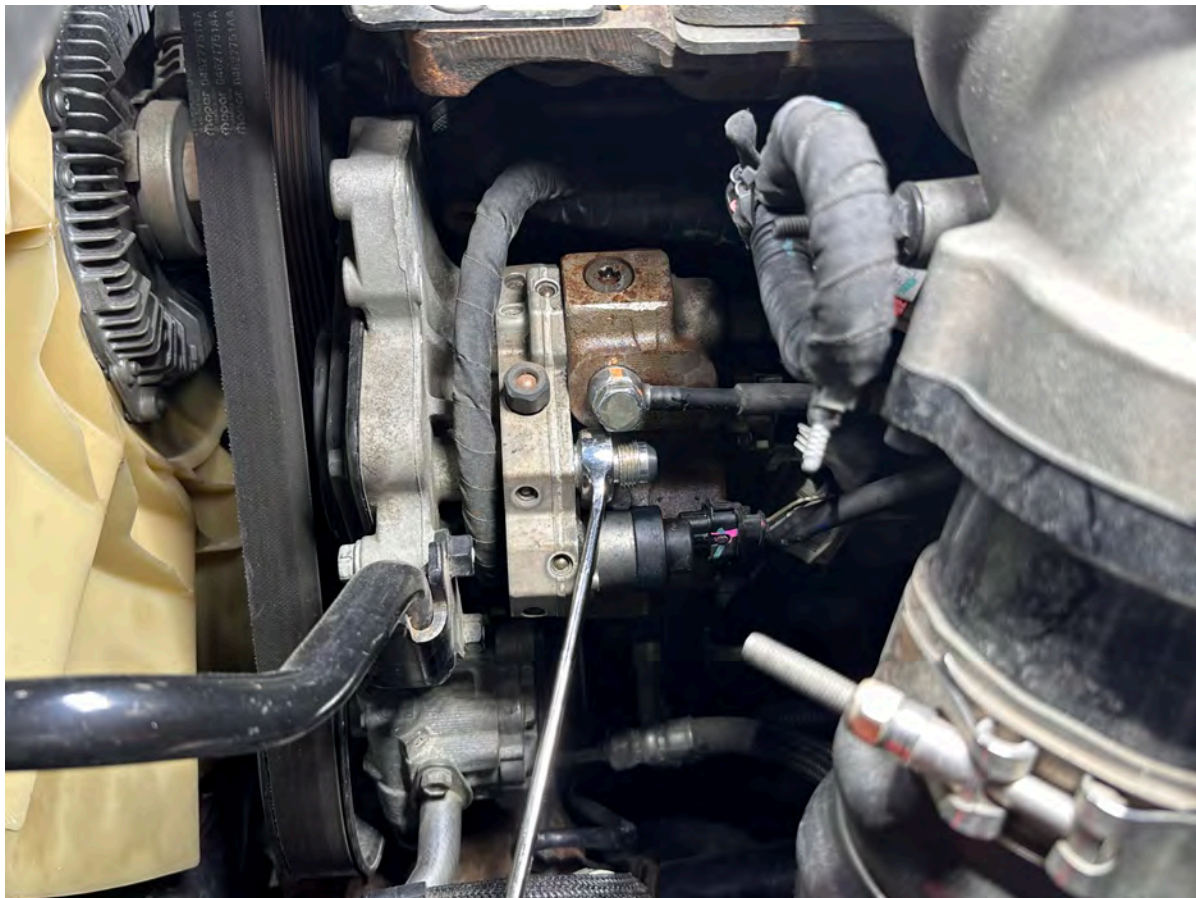

P. Remove the OEM return line fitting from the CP3 to properly tighten PL-1002 to DIPF-1003.



Q. Using grease, press PL-1002 into FL-1001 and tighten onto DIPF-1003. Route FL-1001 to the FASS and trim accordingly.



R. Reinstall the OEM return line fitting onto the CP3 and tighten accordingly.

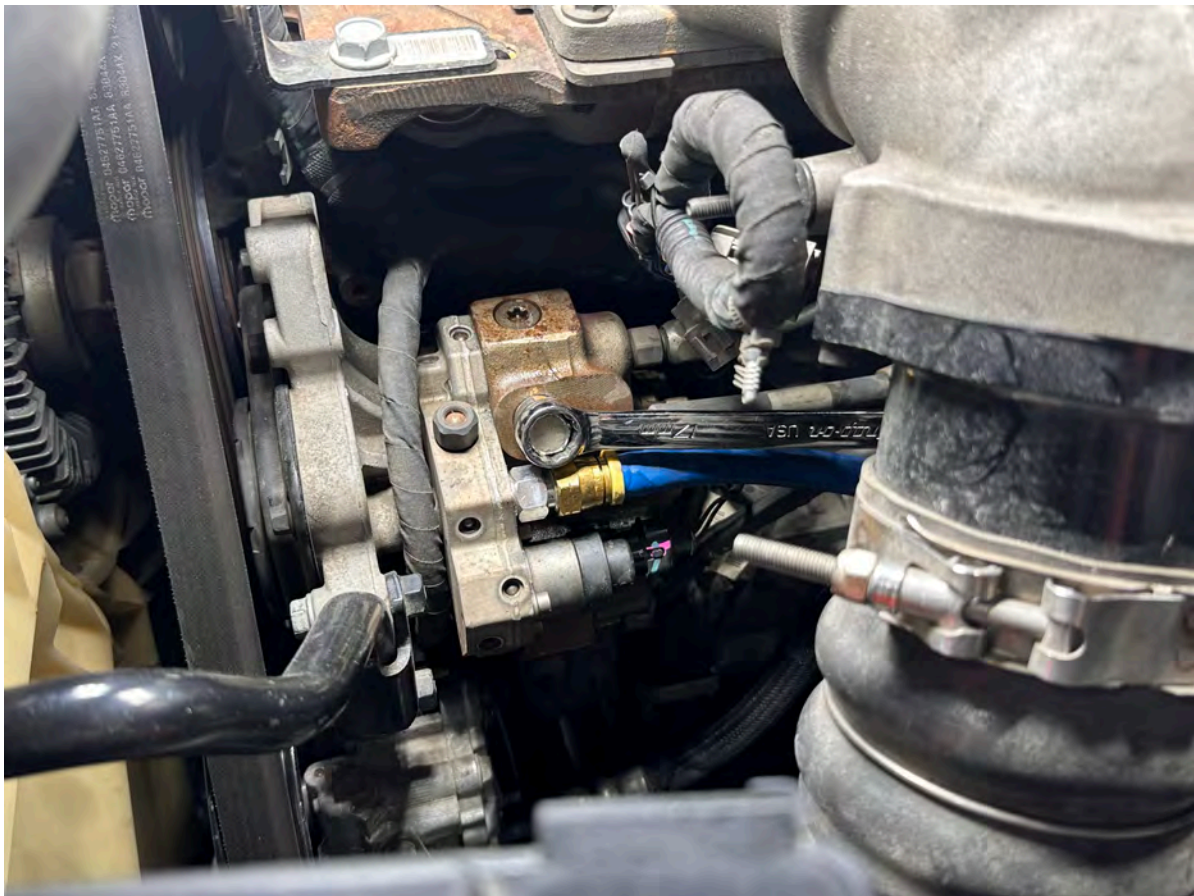

S. Using grease, press A614M53-08-02 into FL-1001 and secure using HC-1001. Install A614M53-08-02 onto the FASS.



T. Disconnect the 5/16" OEM fuel return line fitting located on the driver side frame rail next to the front drive shaft.

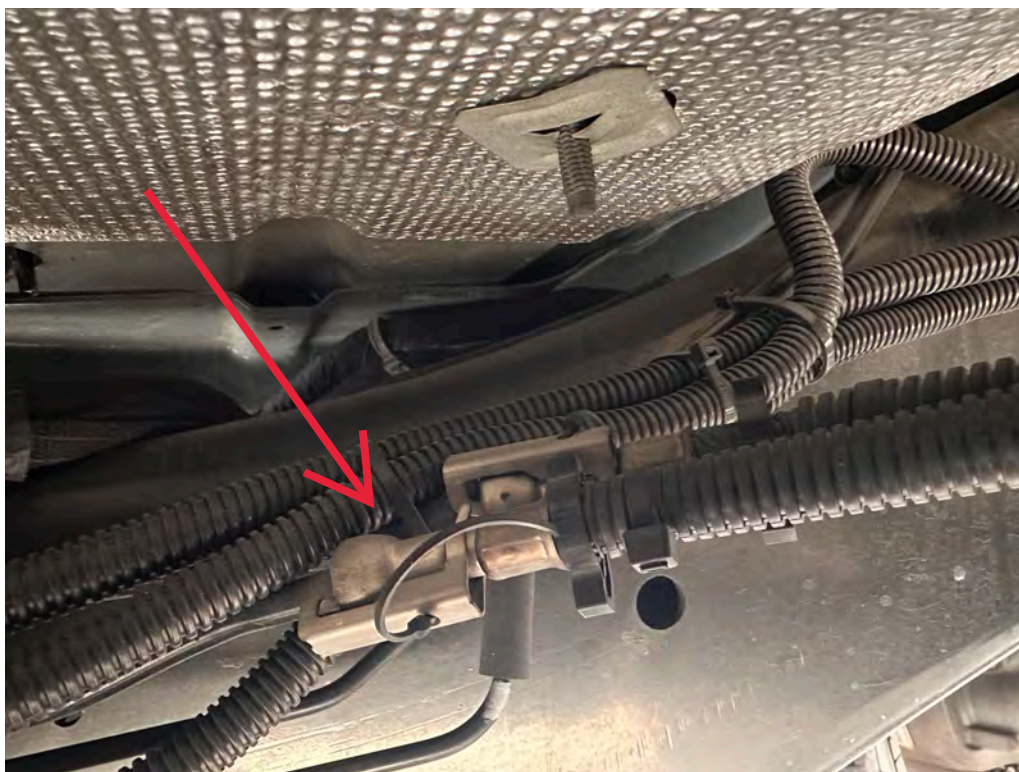

U. Using grease, press QPD3B-05F-04-05M into FL-1010 and secure using HC-4001. Install QPD3B-05F-04-05M onto the OEM quick connect return line and reinstall the OEM quick connect to QPD3B-05F-04-05M. Route FL-1010 to the FASS and trim accordingly.



V. Using grease, press PL-1012 into FL-1010 and connect PL-1012 to the FASS return. Tighten accordingly.

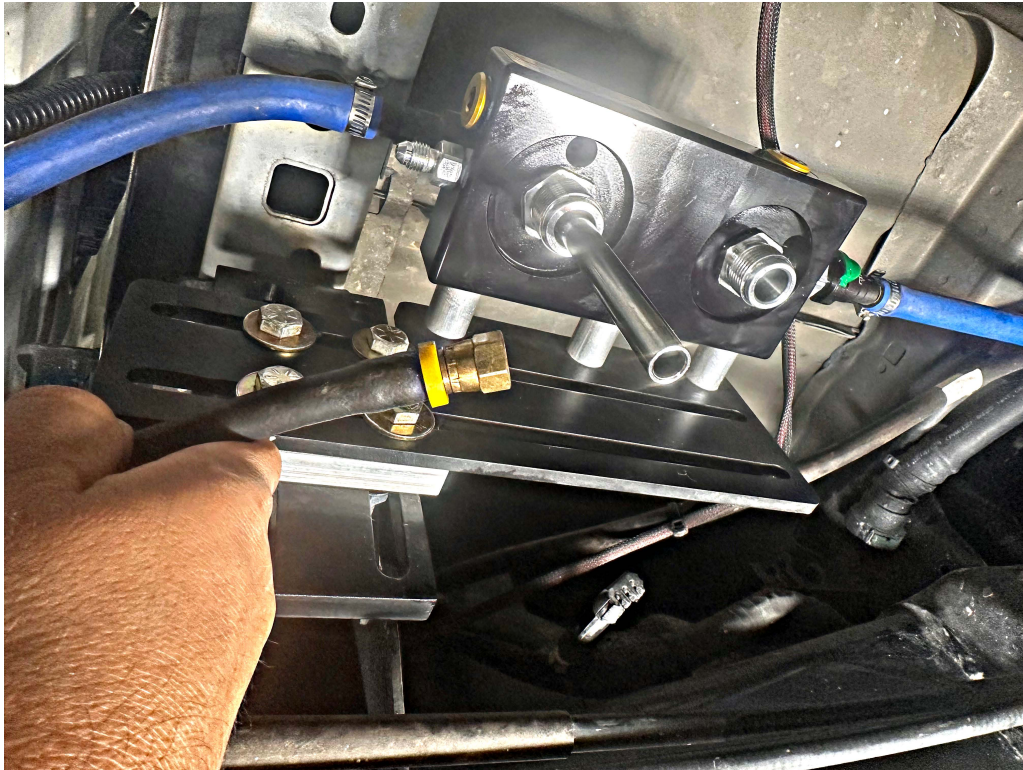

W. Remove the factory WIF sensor connector and connect into DIFS-RAM-WH-1001. Route DIFS-RAM-WH-1001 to the FASS securing DIFS-RAM-WH-1001, FL-1001 and FL-1010 with the supplied cable ties.

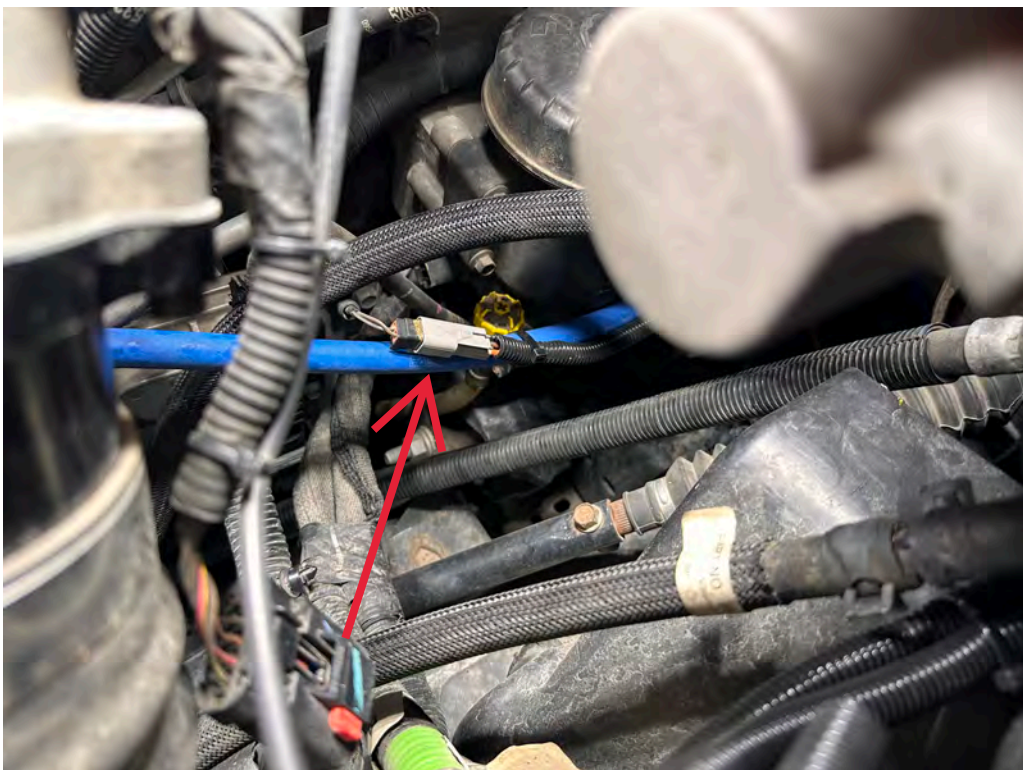
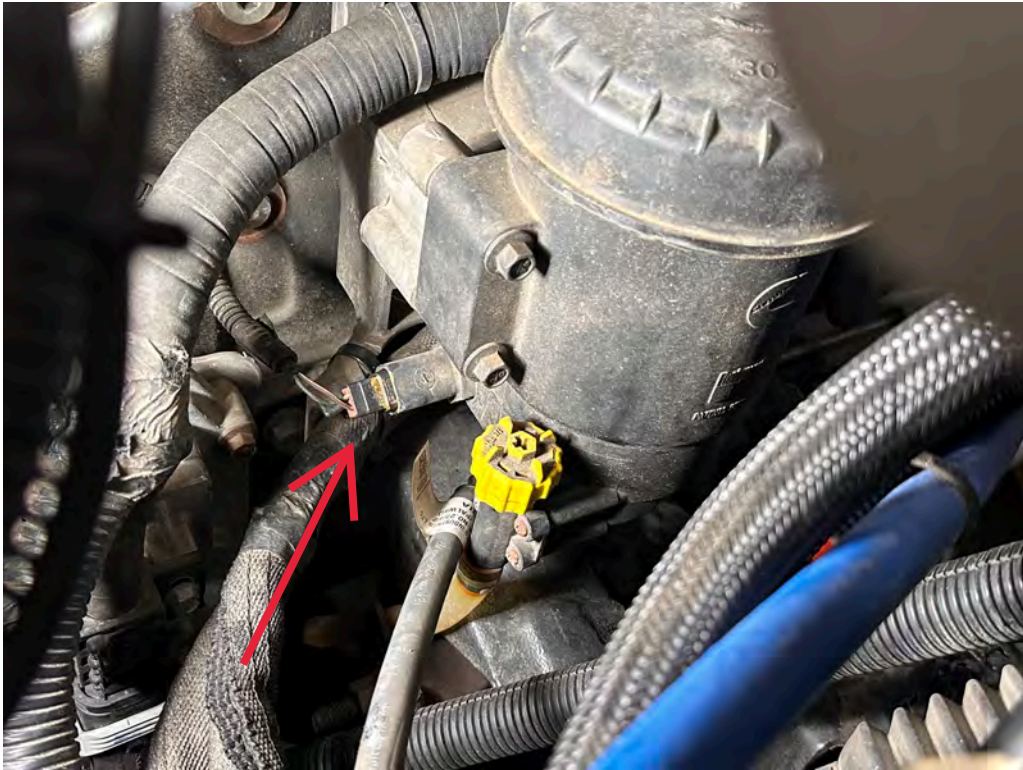

X. Apply grease to the XWS-3002 gasket, then install onto the FASS System.



Y. Install WIFS1002 into the bottom of CWS1010. Apply grease to the CWS1010 gasket, then install onto the FASS System. Connect DIFS-RAM-WH-1001 to WIFS1002.



Z. Prime the fuel system, start the truck, and check for fuel leaks.





www.fassride.com

(866) 769.3747

LIMITATION OF LIFETIME WARRANTY

Disclaimer: To help insure you receive the proper system and customer support at the local level, FASS has a VIP and Authorized Dealer network representing FASS products. This is one reason you must purchase through a dealer to comply with our warranty policies. If you do not, there is no warranty! We recommend you go to www.FASSride.com, click "Find a Dealer", put in their ZIP code, select the type of dealer, and see if the company you purchased from is listed. If they are not, put their phone number in the field below the ZIP code field to see if they are listed. Below these two fields is a list of "Terminated/Unauthorized" dealers. You may want to review this list. If the company is not listed or is on the "Terminated/Unauthorized" list, we suggest you return the product immediately to that dealer and call FASS. We'll recommend you to the nearest dealer.

Diesel Performance Products, Inc. (hereafter "SELLER") gives Limited Warranty as to description, quality, merchantability, fitness for any product's purpose, productiveness, or any other matter of SELLER'S product sold herewith. The SELLER shall be in no way responsible for the product's open use and service and the BUYER hereby waives all rights other than those expressly written herein. This Warranty shall not be extended or varied except by a written instrument signed by SELLER and BUYER.

When MANUFACTURER receives the "ORIGINAL" PRODUCT REGISTRATION form with a copy of the "BILL OF SALE/SALES RECEIPT" within 30 days of the sale, then the following applies! The Warranty will then and only then be validated to that of which typically accompanies your unit for your specific application from the date of sale or for recommended service life and limited solely to the original purchaser and/or vehicle and parts contained within the product's kit. This warranty does not cover normal wear on consumable items such as but not limited to filters, fuel line, wire harness & etc. The warranty does not cover seized gears due to lack of filtration. Warranty is voided if used with other than diesel fuel. Returned items will arrive prepaid to the place of purchase. Diesel Performance Products, Inc. will repair, without cost, any product found to be defective during the warranty period; parts only, or at its option, will replace such products in exchange for the product. Repair or replacements are warranted for the remainder of the original warranty period. All Warranty claims are subject to approval by Diesel Performance Products, Inc.

A Return Material Authorization (RMA) number must be obtained before any product is to be returned to Diesel Performance Products, Inc. for warranty consideration, repair or product return. Requests for product returns must be offset by an equal value order. Return parts must be completed and in resalable condition. No returns after 30 days.

Your Name, Address, and Phone Number's

Model and Serial Number (Not Motor Number) Example: Model HD Series, Serial: 00125966 VIN Number of Vehicle

Date of Purchase

Nature of Problem

RMA and Product Serial Number must be on all paperwork and correspondence. Failure to obtain the required information or paperwork will result in \$25.00/item penalty and delay or denial of any warranty claim.

Under no circumstances shall the SELLER and/or MANUFACTURER be liable for any labor charged or travel time incurred in diagnosis for defects, removal, or reinstallation of this product, or any other contingent expenses.

Under no circumstances shall the SELLER and/or MANUFACTURER be liable for any damage or expenses insured by reason of the use or sale of any such equipment. This warranty does not apply to products which Diesel Performance Products, Inc. has determined to have been misused or abused, improperly maintained by the user, or where the malfunction or defect can be attributed to the use of non-genuine Diesel Performance Products, Inc. parts.

IN THE EVENT THAT THE BUYER DOES NOT AGREE WITH THIS AGREEMENT: THE BUYER MAY PROMPTLY RETURN THIS PRODUCT, IN A NEW AND UNUSED CONDITION, WITH A DATED PROOF OF PURCHASE, TO THE PLACE OF PURCHASE WITHIN THIRTY (30) DAYS FROM DATE OF PURCHASE FOR A FULL REFUND LESS SHIPPING.

THE INSTALLATION OF THIS PRODUCT INDICATES THAT THE BUYER HAS READ AND UNDERSTANDS THIS AGREEMENT AND ACCEPTS ITS TERMS AND CONDITIONS.